

Answer the following questions:

1. Assume that the tablet bottling control system is set for 36 tablets per bottle. Determine the binary numbers in register A and register B after 5 bottles have been filled. If one more bottle is filled, what will be the output of the adder?

2. What full-adder inputs will produce the following outputs?

- (a) $\Sigma = 0, C_{out} = 0$ (b) $\Sigma = 1, C_{out} = 0$
 (c) $\Sigma = 1, C_{out} = 1$ (d) $\Sigma = 0, C_{out} = 1$

3. The input waveforms in the figure below are applied to a 2-bit adder. Determine the waveforms for the sum and the output carry in relation to the inputs by constructing a timing diagram.

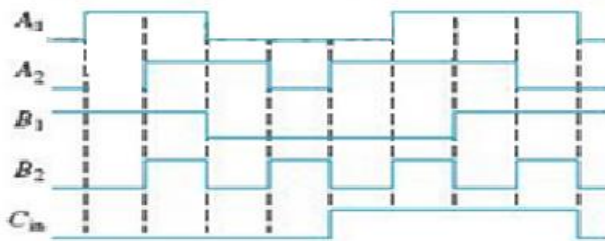

4. In the process of checking a 4-bit parallel adder, the following logic levels are observed on the inputs: HIGH (MSB), HIGH, HIGH, HIGH, and HIGH (MSB), LOW, LOW, HIGH. The following levels are observed on the outputs: LOW (MSB), HIGH, LOW, and HIGH. Determine if the adder is functioning properly.

5. Show the additional logic circuitry necessary to convert the 4-bit look-ahead carry adder in the figure below into a 5-bit adder.

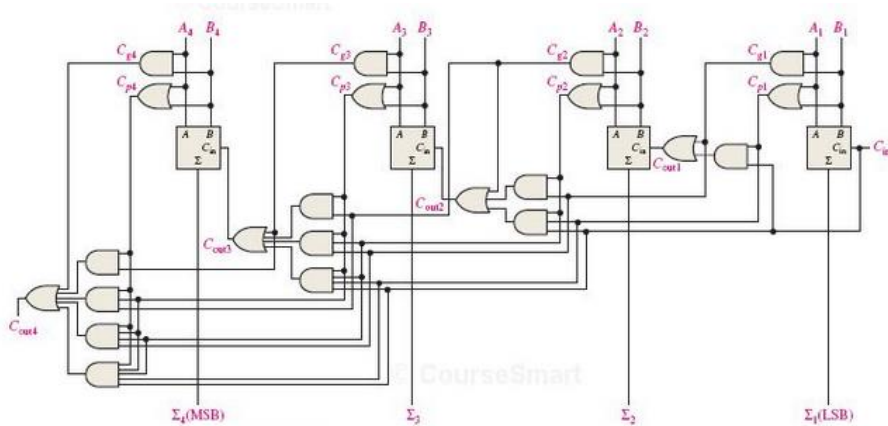

6. When a HIGH is on the output of each of the decoding gates in the figure below, what is the binary code appearing on the inputs? The most significant bit (MSB) is A_3 .

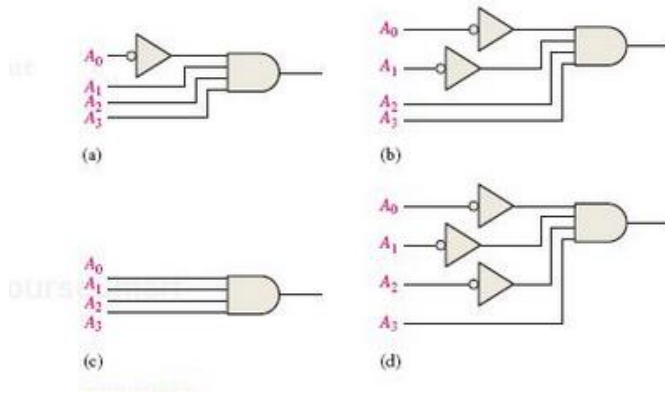

7. A 7-segment decoder/driver drives the display in the figure below. If the waveforms are applied as indicated, determine the sequence of digits that appear on the display.

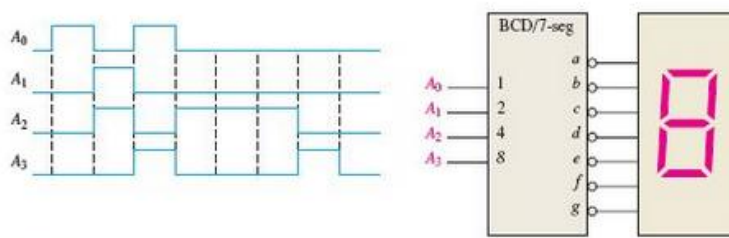

8. A priority encoder has active-LOW levels on inputs 1, 5, and 9. What BCD code appears on the outputs if all the other inputs are HIGH?
9. What is the logic required to convert a 10-bit binary number to Gray code? Use that logic to convert the following binary numbers to Gray code:
 (a) 1010101010 (b) 1111100000 (c) 0000001110 (d) 1111111111

10. The waveforms in the figure below are observed on the inputs of an 8- input multiplexer. Sketch the Y-output waveform.

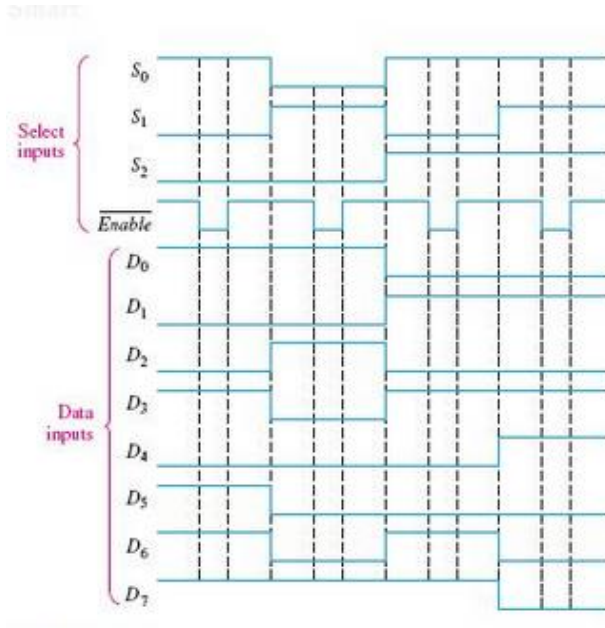

11. The waveforms in the figure below are applied to the 4-bit parity logic. Determine the output waveform in relation to the inputs. For how many bit times does even parity occur and how is it indicated? The timing diagram includes 8 bit times.

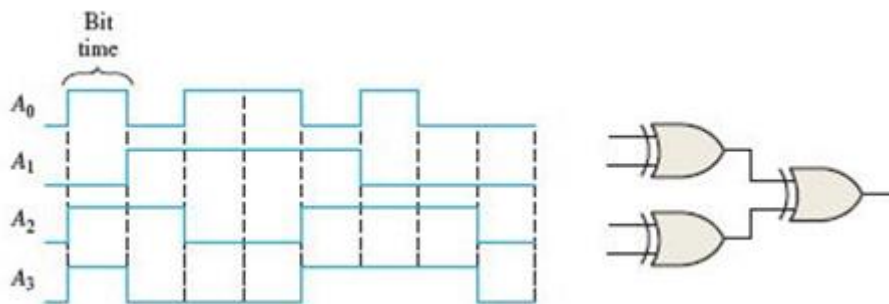

12. What are the components of a computer system bus?
 13. List five devices that connect to a computer using an external bus.

14. Determine the signal on the bus line in the figure below for the data input and enable the waveforms shown.

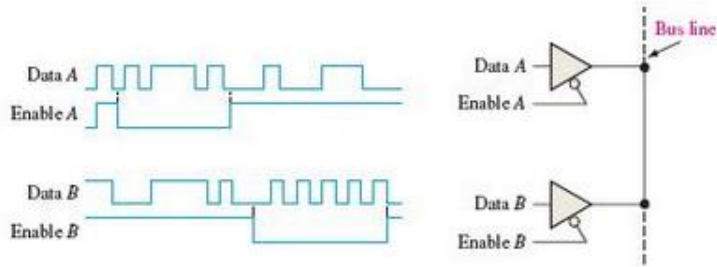
**Submission Requirements:**

Submit your answers in a Microsoft Word document. The submission should use:

- Font: Arial; 12-point
- Line spacing: Double

Evaluation Criteria:

Your submission will be evaluated against the following criteria:

- Did you include appropriate steps or rationale to determine the answers to questions wherever required?
- Did you correctly answer each question?