

Unit 4: Digital Logic Project

Due Sunday by 11:59pm **Points** 100 **Submitting** a file upload

The Unit 4 digital logic project consists of creating a combinational circuit using either Digital Works or Logisim.

Grading

The assignment is worth 100 points: 75 points for the circuit, 15 points for the truth table, and 10 points for the Boolean expressions of the outputs.

Step 1

(75 points) – create the circuit below in either Digital Works or Logisim

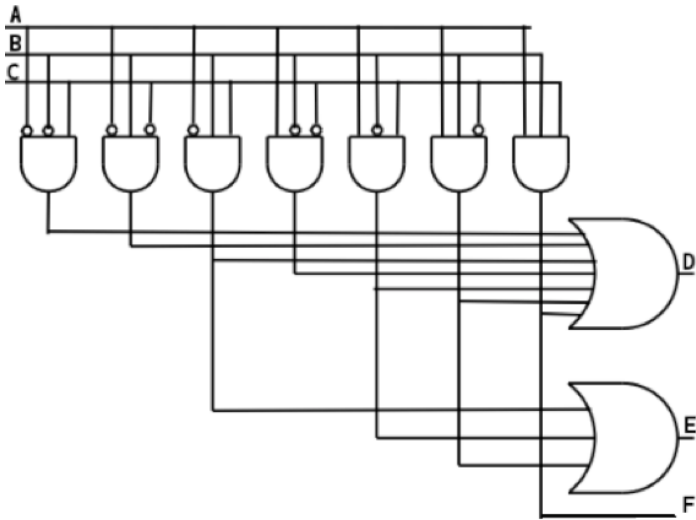

Step 2

Attach interactive inputs to A, B, and C lines of your circuit and LEDs to the outputs D, E, and F.

Digital Works

The interactive inputs on Digital Works will toggle between on and off, and an LED will be red if it receives a logical 1.

Location of interactive input and LED on Digital Works menu

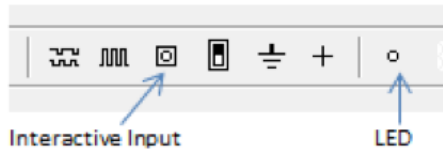

Operation of interactive inputs and LEDs

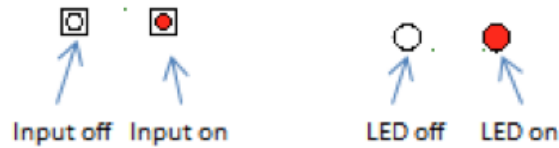

Logisim

The interactive inputs on Logisim will toggle between 0 and 1, and an LED will be red if it receives a logical 1.

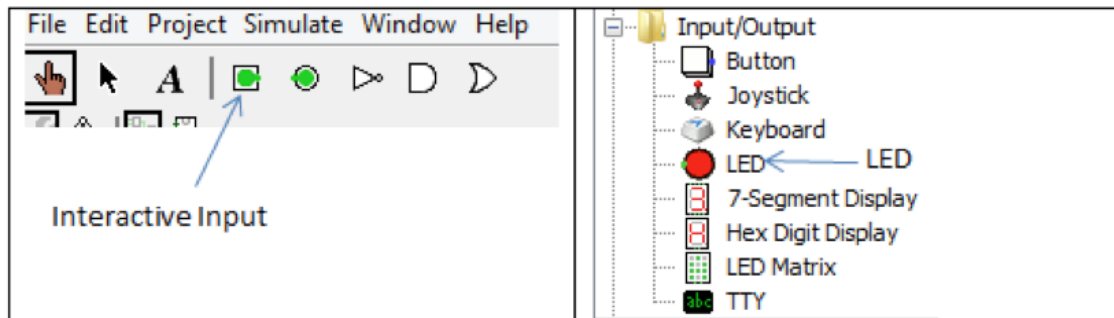

Step 3

Test your circuit by toggling the interactive inputs and observe which of the LEDs light up on the three outputs. Write down which combinations of the three inputs cause specific LEDs to light up. Be sure to go through all combinations of inputs.

Digital Works

To test your circuit, click Circuit on the menu bar, then select Run. To toggle the interactive inputs use the pointer finger tool, and place the finger over the input and left click the mouse.



Use pointer finger to toggle interactive inputs

Logisim

To test your circuit, click Simulate on the menu bar, and make sure Simulation Enabled is checked. To toggle the interactive inputs use the pointer finger tool, and place the finger over the input and left click the mouse.



Use pointer finger to toggle interactive inputs

Step 4

(15 points) – create a truth table for the circuit in a Word document

- create a truth table for the circuit using a table in Microsoft Word. There will be nine columns in the truth table. One for each input signal, one for each output signal, and the last three columns will be for the LEDs (see column headings below). Use 0's and 1's in your truth table for the three inputs and three outputs. If an LED is red for a specific combination of inputs then put "on" in the truth table, and "off" if the LED is not red. You will need to create a separate row in the truth table for each combination of input signals.

A	B	C	D	E	F	D Led	E Led	F Led
---	---	---	---	---	---	-------	-------	-------

Step 5

(10 points) – create Boolean expressions in the same Word document as the truth table

Create three separate Sum of Products Boolean expressions for outputs D, E, and F.

Step 6

Submit the circuit, truth table, and Boolean expressions

Take a screen shot of your circuit and paste it into the Word document containing the truth table and Boolean expressions.

Place the Word document and the simulation file from either Digital Works or Logisim into a zip file and submit the zip file for grading.

File Upload

[Google Doc](#)

Upload a file, or choose a file you've already uploaded.

File:

No file chosen

[Add Another File](#)

[Click here to find a file you've already uploaded](#)

Comments...

Criteria	Ratings			Pts
Circuit Content	All digital logic components are in the circuit, along with LEDs and the circuit organization demonstrates mastery of the simulation software. 75 pts	All digital logic components are in the circuit but it does not contain LEDs for testing. 70 pts	Circuit is missing required components. 40 pts	75 pts
Truth Table	Truth table has all the rows and columns, AND all entries are correct. 15 pts	Truth has all the rows but missing columns, OR has all the columns but missing rows. 14 pts	Truth table is incomplete (missing rows or columns). 5 pts	15 pts
Boolean Expression	Boolean expression has all the items and they are correct. 10 pts	Boolean expression has all the items but there are errors in one or more. 9 pts	Boolean expression is incomplete. 3 pts	10 pts
Total Points: 100				